

**TCM**



**DEBUT!**  
3.5t model.

**Innovative Machine**  
**INOMA**

I.C. Engine-Powered Forklift Trucks  
1.5-3.5 ton  
(Counter-Balanced Type)



# ***INOMA***

Second to None, Revolutionary Forklift Trucks — Freshly Debuted

Succeeding TCM's traditional product concepts of superb performance and quality, we hereby announce a new type of forklift truck, offering incomparable ruggedness and operator-friendly features. It's the newly debuted ***INOMA***. TCM has fully upgraded and redesigned ***INOMA*** for easier access, greater comfort, improved maneuverability, assured safety, and longer durability. Thanks to TCM's outstanding technological expertise and strengths, the ***INOMA*** forklift truck achieves optimum performance for its class while providing outstanding comfort and safety.

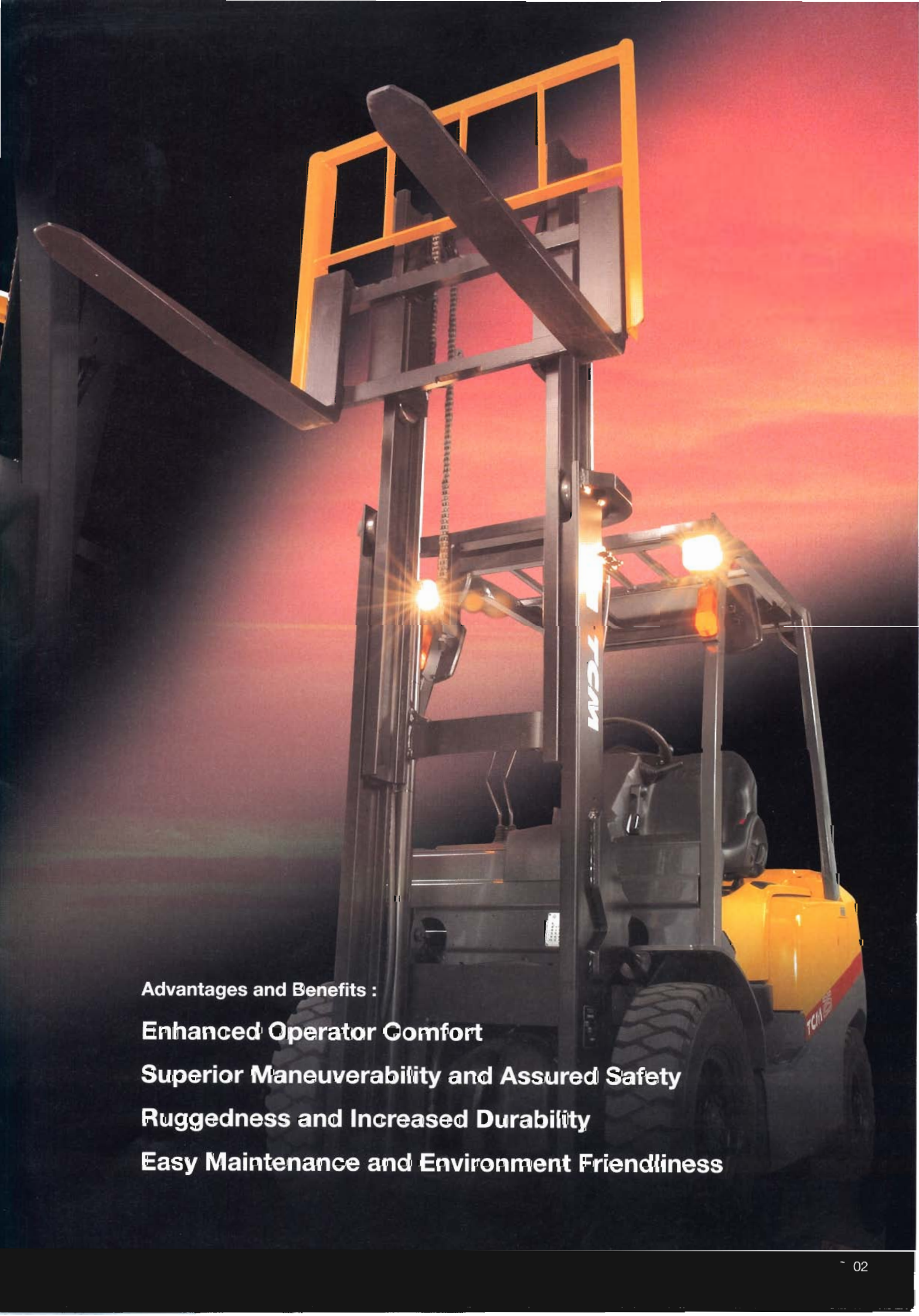

**Advantages and Benefits :**

**Enhanced Operator Comfort**

**Superior Maneuverability and Assured Safety**

**Ruggedness and Increased Durability**

**Easy Maintenance and Environment Friendliness**

# ENHANCED OPERATOR COMFORT

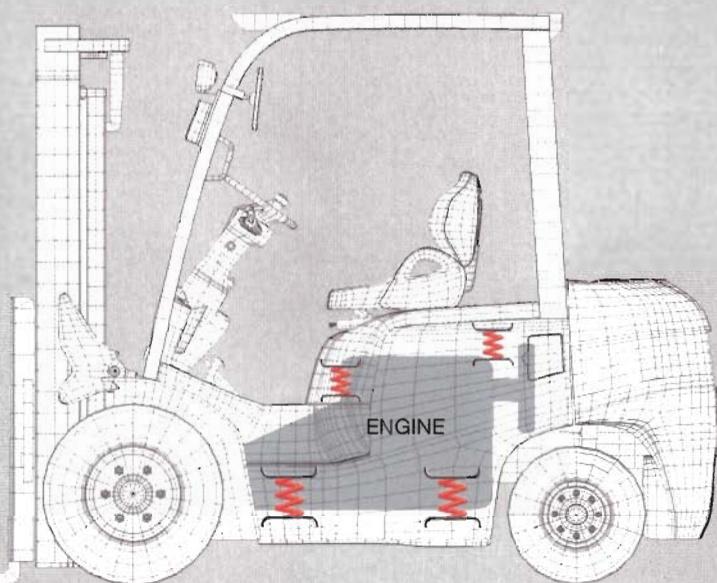

Substantially reduced vibration by adopting dual-floating systems for both the engine and hood

Minimizes the transfer of vibration to the operator, with four-point rubber cushion absorbers between the seat and engine and its transmission. Moreover, use of the same four-point suspension adopted in the hood, realizing a dual effect in reducing vehicle vibrations.



Expansive floor space for easier foot maneuvering

An amazing 45% increase in floor space by placing tilt cylinders under the floor. This gives a smooth footwell in addition to easy entry and exit.



More convenient parking lever

The lever is positioned to the right of the steering wheel for easier entry and exit.

A double-action brake release on the lever further improves safety.



**Easier entry and exit from an extra-wide step— 55% wider**

The secure step with enlarged foot space enables greater comfort and less fatigue while entering and exiting the vehicle.



**Multifunctional suspension seat**

(available for 1.5/1.8ton high power & 2-3.5ton models)

Features include reinforced driver support, reduced vibration, operator weight balance adjusting, forward and backward reclining, a rear utility pocket, and seat belt.



**Resin screen**

The resin screen on the overhead guard enables comfortable outdoor operation in wet weather.



# SUPERIOR MANEUVERABILITY AND ASSURED SAFETY



## Innovative fork-landing mechanism

(available for wide view two-stage mast)

The fork-lowering speed decelerates at a height of approximately 150 mm above the ground enabling accurate placement of the forks into the load fork pockets or pallet.



## Reduced fatigue due to a semi-circular steering wheel

A smaller diameter (300mm outer diameter) steering wheel gives improved vehicle maneuverability. In addition, this compact steering wheel makes it much easier to get on and off the truck.



## Meter panel optimally located to the right of the driver's seat

The meter panel is located on the top right side of the dashboard for easier readability by the operator.



## Multi-cone synchronizer shift levers

The newly adopted levers enable smooth shifting from both forward and reverse (available for manual transmission models).



## EXCELLENT OPERATOR VISIBILITY

### Wider forward visibility

Clearer visibility of the fork tips—50% improvement over other current models. This achievement was made possible by lowering the dashboard by **70mm** and the tie bar by **190mm**. A remarkable improvement of the forward view along with quicker recognition of the fork position. An operator-friendly design with assured safety, high efficiency, and relaxing feel.



### Amazing backward visibility

Reshaped counter weight for better rearview sight. The round shape of the rear top end of the counterweight substantially improves visibility for increased safety during backward movement.

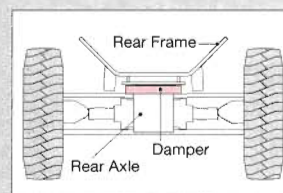

### Anti-roll mechanism for assured safety during turning (available for 2–3.5ton models)

Warning: This system does not guarantee accident avoidance or prevention of vehicle overturning.



### Neutral safety mechanism

This feature enhances safety of operation. The engine cannot be started unless the change lever is in the neutral position.



### High-mounted rear combination lights

The brake lights are easily visible at the top of the overhead guard. Recessed for protection, they are vibration resistant for long bulb life.



### Anti-slip mat on the hood

A rubber strip is attached to the hood to prevent slippage while stepping on and off.



### Meter panel with LED indicators

The LED has a longer life and is easy to read even during daylight shift operation.

# RUGGEDNESS AND INCREASED

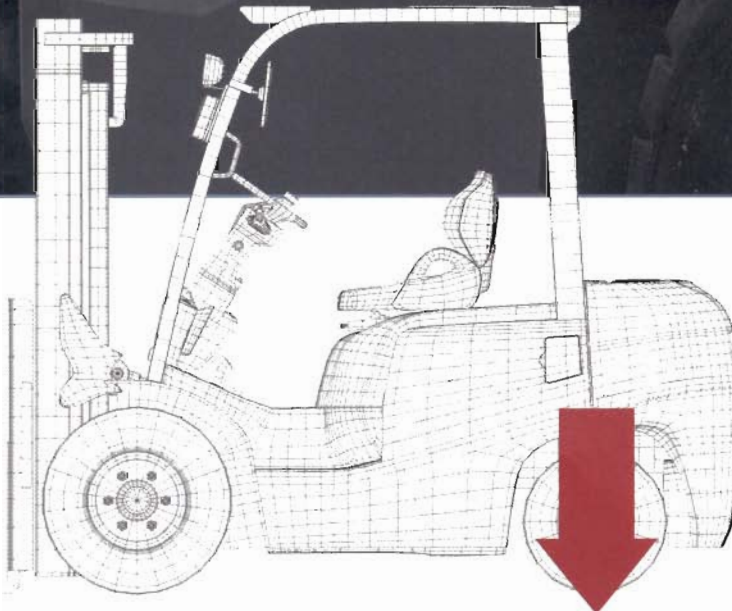

5% improved front and rear stability ratio (available for 2–3.5ton models) Stable and more consistent cargo handling as well as travel due to an improved stability ratio.

# DURABILITY



### Single-piece headguard

The front and rear pillars as well as roof are all welded together in a single-piece construction to give additional strength to the entire structure.

### TCM transmissions

TCM designed and developed these transmissions for quiet operation and maximum durability, and TCM builds them to insure the highest quality.

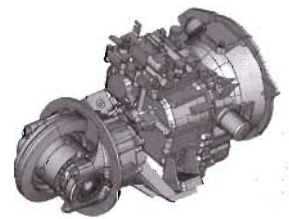

### TCM steering axles

Also a new TCM design, the steer axle has been strengthened and improved for durability in demanding applications.

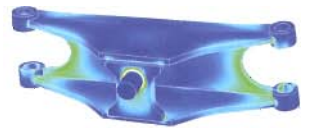

### Sturdier mast

Minimized distortion of the mast by redesigned positioning the mast supports and tilt cylinders. TCM's traditional robust mast was further upgraded by adopting sturdier tie bars, while maintaining a wide range of viewing angles.

### Improved durability with lubricant filled lift cylinder

Oil filled lift cylinders give improved durability.  
(available for 2-3.5ton models)

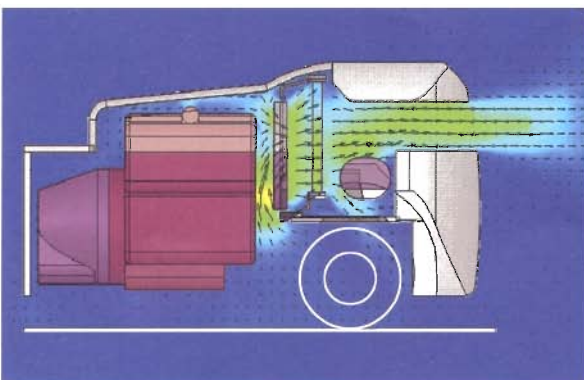
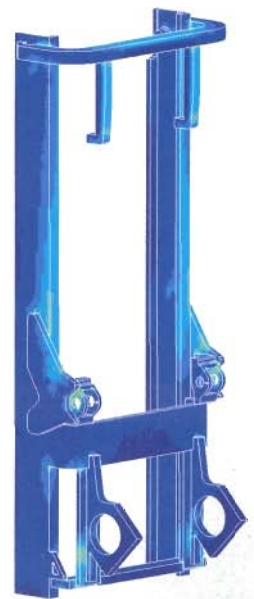

### Cooler running through improved airflow

Optimal positioning of the fan, radiator and muffer has reduced the operating coolant temperature. (gasoline models) The operating temperature of the hydraulic oil has been reduced, also by 10°C by upgrading the mechanical components and circuitry.

# EASY MAINTENANCE AND ENVIRONMENT FRIENDLINESS

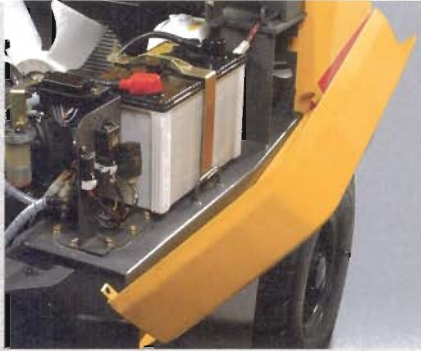

## Detachable side covers for convenient inspection and simple maintenance

Inspection and maintenance can more easily be performed due to one-touch detachable side covers and a wide-opening hood.

## Integral layout of electrical parts and other system devices

Maintenance inspections can be performed more easily, as electrical parts such as the fuse box, relay, and battery are neatly integrated into a conveniently compact area.



## New engines, compliant with worldwide 2<sup>nd</sup> stage emission regulations

Powerful, yet appropriate, diesel engines, compliant with stringent global emissions regulations.



## One-piece floorboard

Gives more convenient inspection and easier maintenance, as the one-piece floorboard unit is easily detachable without using any tools.



Portable glove box



Detachable and portable.

Cup holder



Convenient for keeping cups, pens, and other small items.



## NEW OPTIONAL EQUIPMENT



**Three-stage mast with four-cylinder mechanism** (available for 2–3ton models)

The cylinders are symmetrically located to the left and right for improved forward visibility.



**Integral side shifter**

A major improvement in the integral side shifter ensures less load loss and improved forward visibility.



**Low-noise mast** (available for 2–3ton models)

Reduced noise from the fork and carriage significantly reduces chain shudder.

**Lift lock**

When the engine is off, the forks cannot be lowered, even when the operator is in the seat.

**Interlock system**

This safety device allows traveling and loading/unloading only when the operator is in the seat.

## OTHER OPTIONAL EQUIPMENT



Rotating warning light



Rear working light



Overhead exhaust system



Windshield wiper



Cabin-panel type  
(available for 2-3.5ton models)



Heater



LPG exclusive/Dual fuel  
(LPG/gasoline) package



Pre-cleaner engine air intake



Steel cabin-enclosed type with air-cooler  
(available for 2-3.5ton models)



Head light guard



Air Boss tire

\* As far as the detailed optional information is concerned, please refer to the specification sheets.  
For various types of attachments, please also refer to the "attachment catalogue" which is separately prepared from this sales catalogue.

# iNOMA Lineup

TCM has been engaged in manufacturing various forklift truck models that take into account the needs and requirements of our valued customers. Now, TCM proudly presents the "iNOMA series" with such benefits as enhanced operator comfort, superior safety assurance, ruggedness and increased durability as well as easy maintenance and environment friendliness. These notable benefits are backed by TCM's many years of experience and superb technological innovations, and TCM is confident in placing the full "iNOMA series" product line on various job sites in markets around the world.



**[1.5 ton]**

FG15C13	FD15C13	FHD15C3
FG15T13	FD15T13	FHD15T3
FHG15C3		FHD15C3Z
FHG15T3		FHD15T3Z

**[1.8 ton]**

FG18C13	FD18C13	FHD18C3
FG18T13	FD18T13	FHD18T3
FHG18C3		FHD18C3Z
FHG18T3		FHD18T3Z



**[2.0 ton]**

FG20C3	FD20C3	FHD20C3
FG20T3	FD20T3	FHD20T3
FHG20C3	FD20C3Z	
FHG20T3	FD20T3Z	

**[2.5 ton]**

FG25C3	FD25C3	FHD25C3
FG25T3	FD25T3	FHD25T3
FHG25C3	FD25C3Z	
FHG25T3	FD25T3Z	



**[3.0 ton]**

FG30C3	FD30C3	FHD30C3
FG30T3	FD30T3	FHD30T3
FHG30C3	FD30C3Z	
FHG30T3	FD30T3Z	



**DEBUT!**  
3.5t model.

**[3.5 ton]**

FD35T3S
---------

# INOMA

- TCM retains the right to change these products and specifications without incurring any obligation relating to such changes.
- These products and specifications are subject to change without notice.
- Photos and illustrations may or may not include optional equipment and accessories.
- Features and specifications may vary depending on markets.



ISO 9001 Certification  
(TCM Shiga Plant)



ISO 14001 Certification  
(TCM Shiga Plant)

Manufactured by

**TCM**  
TCM CORPORATION

1-15-5 Nishi-Shimbashi, Minato-ku,  
Tokyo 105-0003 Japan  
Tel :+81 3 3591 8176  
Fax:+81 3 3591 8152  
www.tcmglobal .net

Distributed by