

CROWN

RT 3500 SERIES

Specifications

Rider Pallet Truck



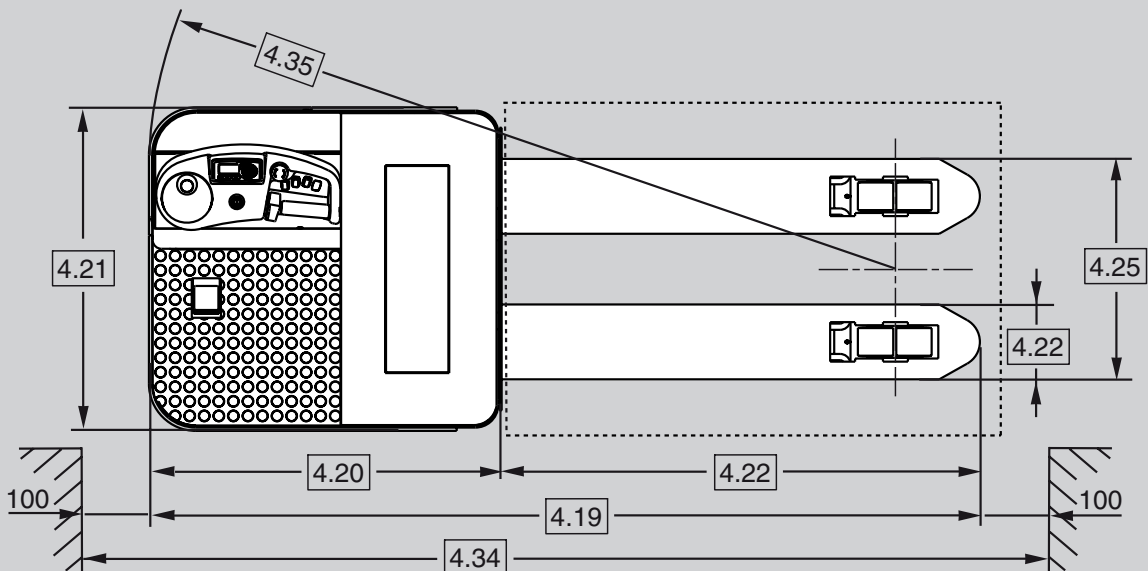
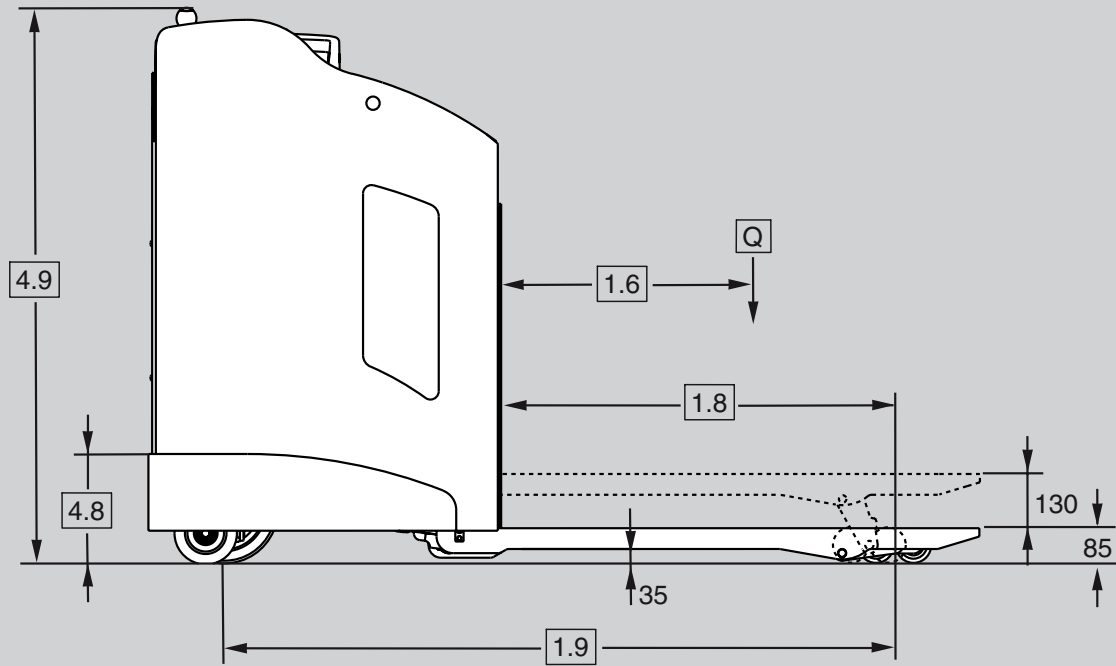

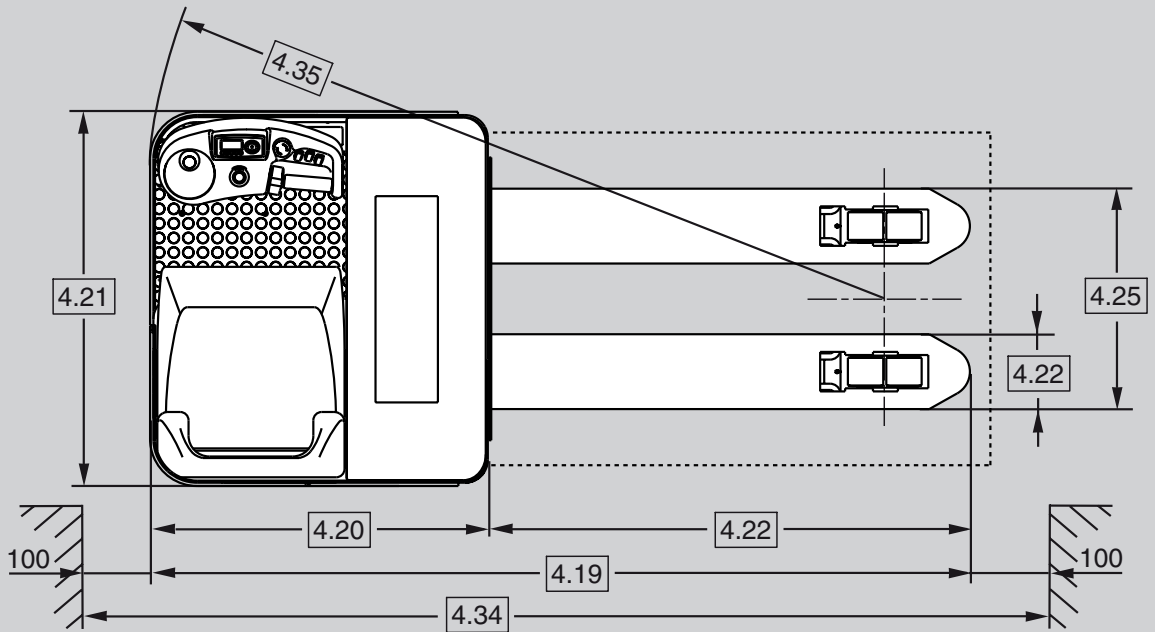
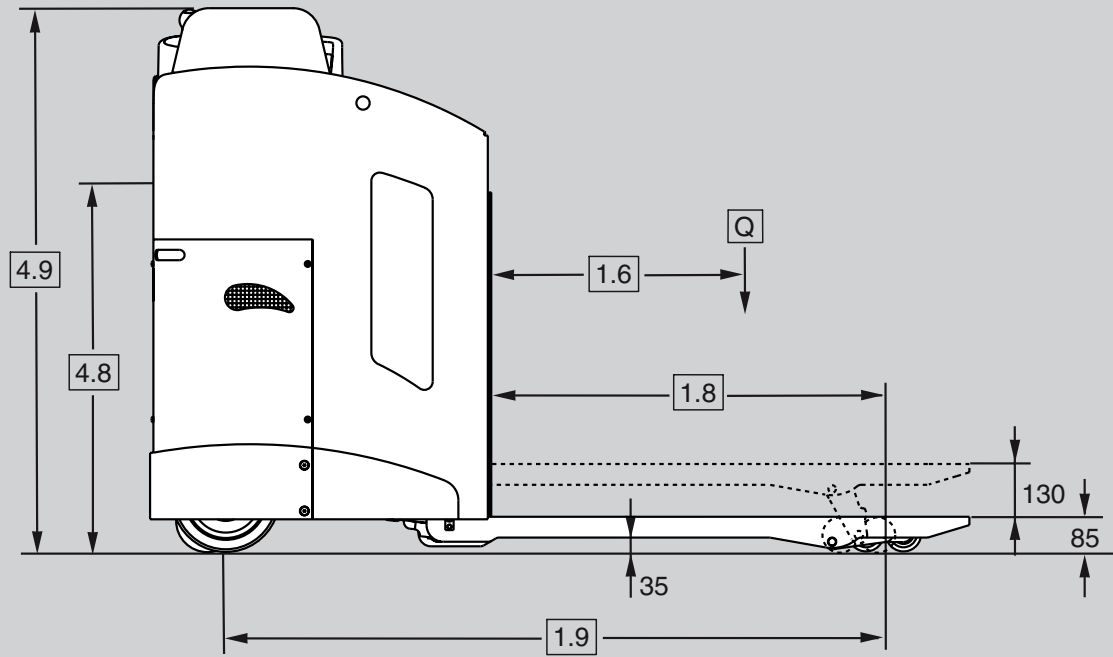

General Information	1.1	Manufacturer	Crown Equipment Corporation						
	1.2	Model				RT 3510-2.0	RT 3520-2.2		
	1.3	Power				electric			
	1.4	Operator Type				stand-on	sit-on		
	1.5	Load Capacity		Q	t	2.0	2.2		
	1.6	Load Centre		c	mm	600			
	1.8	Load Distance *	forks raised	x	mm	882			
	1.9	Wheel Base *	forks raised	y	mm	1548	1520		
	Weights	2.1	Weight	less battery		kg	590	579	
2.2		Axle Load	w. load, front / rear		kg	1114 / 1856	1139 / 1991		
2.3		Axle Load	w.o. load, front / rear		kg	660 / 220	640 / 200		
Tyres	3.1	Tyres Type				Vulkollan			
	3.2	Wheel Size	front		mm	Ø 260 x 85			
	3.3	Wheel Size	rear		mm	Ø 85 x 70			
	3.4	Additional Wheels	castor wheel		mm	Ø 150 x 50			
	3.5	Wheels	number (x=driven) front/rear			1x + 2/4			
	3.6	Track Width	front	b10	mm	442	573		
	3.7	Track Width	rear	b11	mm	350 / 470			
Dimensions	4.4	Lift Height		h3	mm	130			
	4.8	Operator Stand/Seat Height		h7	mm	265	925		
	4.9	Steering Wheel Height	in drive position		h14	mm	1336	1330	
	4.15	Fork Height	lowered		h13	mm	85		
	4.19	Overall Length		l1	mm	2000	1970		
	4.20	Headlength		l2	mm	850	820		
	4.21	Overall Width		b1	mm	770	900		
	4.22	Fork Dimension	standard	thxwxl	mm	50 x 180 x 1150			
	4.25	Width Across Forks		b5	mm	530 / 650			
	4.32	Ground Clearance	centre of wheelbase		m2	mm	35		
	4.34	Working Aisle Width	800x1200 mm length, forks raised	Ast	mm	2273	2256		
4.35	Turning Radius *	forks raised	Wa	mm	1755	1738			
Performance	5.1	Travel Speed	w. / w.o. load		km/h	10 / 11			
	5.2	Lift Speed	w. / w.o. load		m/s	0.06 / 0.08	0.04 / 0.06		
	5.3	Lowering Speed	w. / w.o. load		m/s	0.09 / 0.08	0.05 / 0.05		
	5.8	Max. Gradeability	w. / w.o. load, 5 min. rating		%	8 / 17			
	5.10	Service Brake				electric			
Motors	6.1	Traction Motor	60 min. rating		kW	2.0			
	6.2	Lift Motor	15% on time		kW	2.0			
	6.4	Battery Voltage	nominal capacity 5h rating		V / Ah	24 / 375	24 / 500 **	24 / 315	24 / 500 **
	6.5	Battery Weight			kg	290	368	261	380
	8.1	Type Controller	drive			AC traction			

* Forks lowered + 64 mm

** U-shape battery only lift out

Electric System / Batteries

24-volt electrical system with nominal battery capacities from 315 Ah to 500 Ah.

Battery lift out is standard. With optional battery compartment rollers the battery can be removed horizontally to one side (315Ah or 375Ah only).

Standard Equipment

1. AC traction and steering motor and control system
2. CAN-Bus technology
3. Electronic steering
4. Speed reduction in turns
5. Self levelling load wheels
6. Armrest
7. Braking system offers frictionless and regenerative electric braking
8. Key switch
9. Information Display
 - LCD display
 - PIN code access capable
 - Travel direction indicator
 - Hour meter and alarm
 - Battery discharge indicator
 - 3 selectable traction performance profiles P1, P2 and P3
10. Storage compartments
11. Cushioned floor mat with integrated presence switch
12. Steel power unit doors
13. SBE 160 red battery connector
14. Emergency power disconnect

15. Vulkollan drive tyre, castor and tandem load wheels
16. Cushioned backrest (3510 only)
17. Seat features a suspension which is adjustable for operator weight, and an adjustable lumbar support (3520 only)
18. Horn

Optional Equipment

1. Single load wheels
2. Battery compartment rollers
3. SBE 160 grey, SB 175 red and DIN 160A red battery connector
4. Freezer conditioning
5. Drive tyre options
6. Fork length and spread options
7. Pallet entry rollers
8. Audible travel alarm
9. Flashing beacon
10. Power supply 12V
11. Headrest (3520 only)
12. Seat in cloth or velour (3520 only)
13. Bottle holder

Operator Area and Controls

The RT 3500 Series incorporates numerous design features to improve operator comfort and productivity. The side-stance position provides the operator with maximum visibility in both directions. The cushioned floor mat absorbs shock and vibration to reduce operator fatigue. The presence switch has a low-profile design and is flush with the floor mat when depressed.

An ergonomic seat on the RT 3520 keeps operators comfortably at work on fast-paced tasks and transports. The standard seat features a suspension which is adjustable for operator weight, adjustable lumbar support, separate armrest and optional headrest. A solid handgrip with easy-to-reach forward/reverse travel switch provides excellent control for the operator during travel, plugging, braking and steering with angled steer wheel with full-time power steering.

A key switch prevents unauthorised operation of the truck. In addition, the display can be configured to require an authorisation PIN code. The information display panel provides concise, clear feedback for the operator during truck operation.

Control System

The electronic control modules communicate via a CAN-Bus (Control Area Network). The system monitors all on-board systems, makes decisions based on the sensor readings, and subsequently controls all truck movements safely and smoothly.

Drive System

The AC traction system delivers high travel speeds and strong acceleration combined with virtually frictionless and regenerative braking. The standard speed reduction in turns provides smooth travel speed transition as steer angle changes.

Steering

Standard on the RT 3500 Series is electronic steering that is microprocessor based. Steering wheel rotation provides minimal steering effort. Drive wheel rotates a full 180° for maximum manoeuvrability. Travel direction indicator keeps the operator up to date.

Power Unit

Power unit is fabricated from heavy-gauge steel. The compartment cradles the operator with a wrap-around chassis while the cushioned floor mat provides maximum comfort. Rugged steel doors protect internal power unit components. The removable panels offer unrestricted service access. Battery side cover is steel. A battery top cover provides service access for charging and watering.

Fork / Lift Mechanism

A fork-levelling system features a sturdy articulating linkage that allows load wheels to raise or lower independently of each other, improving traction by adjusting for uneven surfaces.

Safety Regulations

Conforms to European safety standards. Dimensions and performance data given may vary due to manufacturing tolerances. Performance is based on an average size vehicle and is affected by weight, condition of truck, how it is equipped and the conditions of the operating area. Crown products and specifications are subject to change without notice.

